

CISCOM7220-4GF Series

20-Port Layer 2 Gigabit Managed DIN Rail Industrial Ethernet Switch



- Support 4 Gigabit SFP ports and 16 100M Ethernet ports, providing flexible networking options
- Support ring redundancy protocols like CS-Ring v1/v2, ERPS, STP/RSTP to enhance network reliability
- Fast ring redundancy with less than 20ms (CS-Ringv1/v2) improves system communication reliability
- Support QoS (Quality of Service) with prioritization mapping based on 802.1P/DSCP/port, improving communication quality
- Support 1 AC 85~264V/DC 110~370V power input or optional dual DC 9~60V power inputs, enabling power redundancy with dual inputs
- High-strength aluminum alloy housing with IP40 protection rating, fanless heat dissipation, allowing the device to operate reliably in harsh environments ranging from -40°C to +75°C

Product Description

CISCOM7220-4GF series is an industrial Ethernet switch designed for industrial applications. It supports 4 Gigabit SFP ports and 16 100M Ethernet ports. This switch utilizes a store-and-forward mechanism, providing robust bandwidth processing capabilities while automatically detecting and reducing transmission errors, ensuring stable, reliable, and efficient data transfer. The product features carefully selected industrial-grade components, high-standard system design, and production control. It is designed for 35mm standard DIN rail installation, housed in a rugged and durable high-strength metal enclosure. The fanless design allows it to dissipate heat effectively and operate reliably in a wide temperature range from -40°C to +75°C. The device also adheres to high industrial protection standards, making it suitable for challenging work environments, ensuring stable communication performance.

CISCOM7220-4GF series supports a range of features and network protocols, including CS-Ring v1/v2, ERPS, STP/RSTP, VLAN, LACP, LLDP, SNMPv1/v2c/v3, RMON, QoS, 802.1X, IGMP Snooping, ACL, WEB/TELNET/SSH access control, static aggregation, port mirroring, static MAC address binding, network diagnostics, loopback detection, email logs, alarms, SNTP, system logs, and online firmware upgrades. These capabilities enhance network performance, reliability, and security, making it suitable for various complex network requirements. The product has undergone rigorous testing for functionality, temperature resilience, safety compliance, and electromagnetic compatibility (EMC).

Product Features

- Support rate limiting for broadcast, unknown multicast, and unknown unicast packets, with detection and prevention of broadcast and multicast packet storms to avoid network storms
- Support link static aggregation and LACP dynamic aggregation to increase transmission bandwidth and enhance link reliability
- Support port mirroring to collect data from port ingress and egress for network detection and fault management
- Support 802.1Q VLAN, providing Access, Trunk, and Hybrid interfaces for easy division of multiple broadcast domains, enhancing network security
- Support IGMP Snooping to establish a Layer 2 multicast forwarding table, reducing multicast data broadcast in the network, and conserving network resources
- Support LLDP (Link Layer Discovery Protocol) for obtaining LLDP neighbor device information, monitoring link statuses, facilitating topology management, and fault localization
- Support ERPS (Ethernet Ring Protection Switching) for multiple ring network protection, link backup, fast convergence, and improved network stability
- Support RSTP (Rapid Spanning Tree Protocol) compatible with STP (Spanning Tree Protocol) to eliminate network loops and enhance network reliability
- Support WEB control with HTTP and HTTPS protocol access control, as well as login IP address restrictions
- Support SNMPv1/v2c/v3 centralized management and SNMPv1/v2c/v3 TRAP messages, including support for standard TRAP and private TRAP notifications
- Support RMON (Remote Monitoring) for remote network monitoring, statistics, and alarms for various types of data frames, suitable for remote monitoring and management in network management systems
- Support QoS (Quality of Service) to prioritize voice, video, and critical data transmission within network devices, addressing network congestion
- Support ACL (Access Control List) with customizable filtering rules for various frame types, enabling filtering or rate limiting of specific packets
- Support 802.1X port authentication for user authentication upon network access, providing local and RADIUS login authentication
- Support alarm functions, including power supply failure, network storms, and port disconnection alarms
- Support loopback detection to prevent network loops and associated network storms
- Support system log information recording, downloading, and categorization, with output available through WEB pages, log hosts, and consoles

Technical Specifications

Software	
Switching	<p>Support port configuration, port rate limiting, storm suppression, storm detection, port aggregation, LACP, and port statistics</p> <p>Support 802.1Q VLAN and port isolation</p> <p>Support MAC address aging and static MAC address binding</p>
Redundancy	<p>Support CS-Ringv1/v2 proprietary ring network technology</p> <p>Support ERPS (Ethernet Ring Protection Switching)</p> <p>Support RSTP (Rapid Spanning Tree Protocol) and is compatible with STP (Spanning Tree Protocol)</p>
Multicast	<p>Support IGMP Snooping</p> <p>Support static multicast MAC address binding</p>
Security Management	<p>Support WEB, TELNET, and SSH access control</p> <p>Support ACL (Access Control List) for filtering traffic</p> <p>Support 802.1X port authentication</p> <p>Support loopback detection, alarms, and Email logging</p>
Management and Maintenance	<p>Support QoS (Quality of Service), SNMP v1/v2c/v3, SNMPv1/v2c/v3 TRAP, RMON, and LLDP</p> <p>Support port mirroring and ping</p> <p>Support user privilege management, system logs, local/network time synchronization, and daylight saving time</p> <p>Support online restart, factory reset, system upgrade, and configuration file upload/download</p> <p>Support CS-NMPv2, CSView management</p>
Switch Capability	
Processing Type	Store and Forward
Backplane Bandwidth	12.8Gbps
Buffer Size	4.1Mbit
MAC Table Size	8K
Interface	
Gigabit Fiber Port	4*1000Base-X Gigabit SFP ports, compatible with 100Base-FX
100M Fiber Port	0/4/8 100Base-FX 100M fiber ports are optional, single-mode/multi-mode, SC/FC/ST, wavelength, and transmission distance are optional.

10/100M Copper Port	16/12/8 10/100Base-T(X) auto-sensing copper ports, supporting full/half duplex, auto MDI/MDI-X
Relay	1 relay alarm output with 3-pin 3.81mm spacing and locking terminal connectors.
CONSOLE	1 CONSOLE port with an RJ45 connector, supporting RS232 signal for device debugging and command configuration
Status LED	Power indicator, operation indicator, alarm indicator, interface indicator, and Ethernet port speed indicator
Power Supply	
Input Voltage	DC model: DC9~60V, dual power input, non-polar AC model: AC85~264V/DC110~370V
Power Consumption	<12W@DC24V(16T) <14W@DC24V(4F), <16W@DC24V(8F)
Connection	5.08mm pitch 5-pin terminal block
Physical Characteristics	
Dimensions	160×74×122(mm) (DIN rail mounting clip excluded)
Installations	Standard 35mm DIN rail installation
IP Code	IP40
Weight	1.2kg
Working Environment	
Operating Temp	-40℃~+75℃
Storage Temp	-40℃~+85℃
Relative Humidity	5%~95% (non-condensing)
Industry Standard	
EMC	IEC 61000-4-2 (ESD): Level 4 IEC 61000-4-5 (Surge): Level 4 * Ethernet ports support 6kV surge protection IEC 61000-4-4 (EFT): Level 4
Certification	CE, FCC, RoHS

Dimensions

Unit: mm

CISCOM7220-4GF

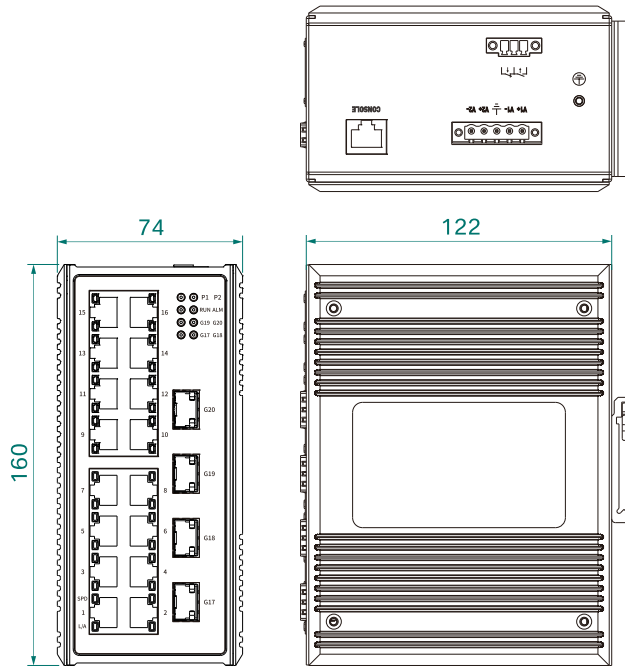

CISCOM7220-4GF-4F

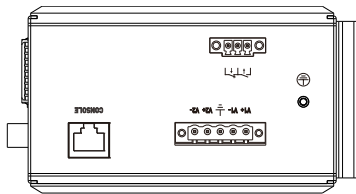

CISCOM7220-4GF-8F

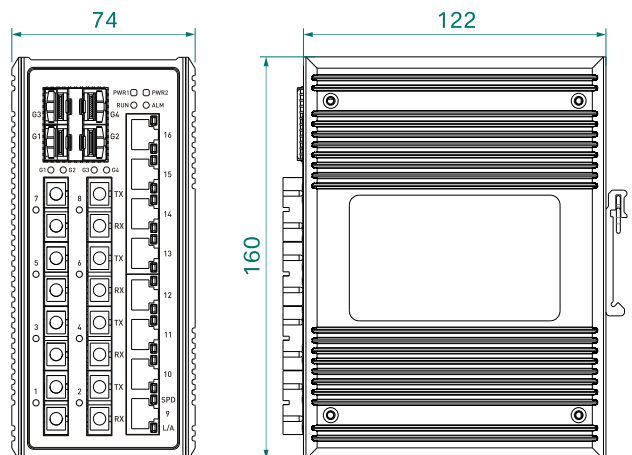
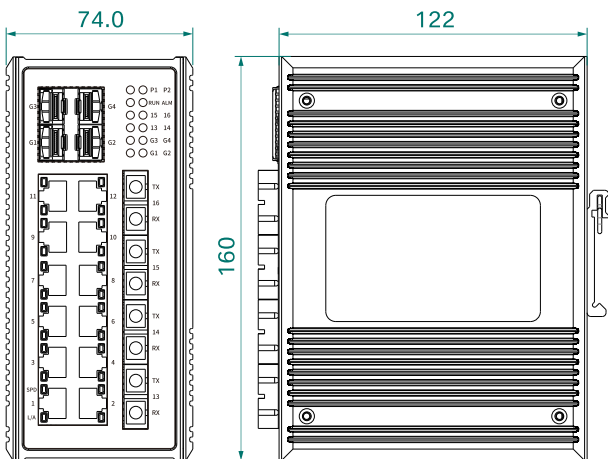
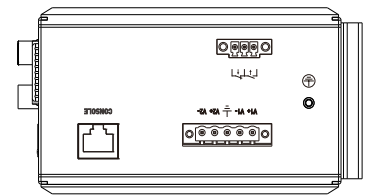

Ordering Information

Standard Model	1G Fiber Port	100M Copper Port	100M Fiber Port	Input Voltage
CISCOM7220-4GF	4	16	/	Dual DC9~60V power input
CISCOM7220-4GF-AD220	4	16	/	AC85~264V/ DC110~370V
CISCOM7220-4GF-4F(M/S)-DC12	4	4	12	Dual DC9~18V power input
CISCOM7220-4GF-8F(M/S)-DC12	4	8	8	
CISCOM7220-4GF-4F(M/S)-DC24	4	4	12	Dual DC18~36V power input
CISCOM7220-4GF-8F(M/S)-DC24	4	8	8	
CISCOM7220-4GF-4F(M/S)-DC48	4	4	12	Dual DC36~72V power input
CISCOM7220-4GF-8F(M/S)-DC48	4	8	8	
CISCOM7220-4GF-4F(M/S)-AD220	4	4	12	AC85~264V/ DC110~370V

Contact Us

COME-STAR COMMUNICATION(WUHAN) CO., LTD.

Address: Puneng Industrial Park, Fenghuang Garden 1st Road, East Lake High-Tech Development Zone, Wuhan, China.

Tel: +86-027-59257958

Mail: info@come-star.com

Official site: www.come-star.com

Copyright © Come-Star All rights reserved